

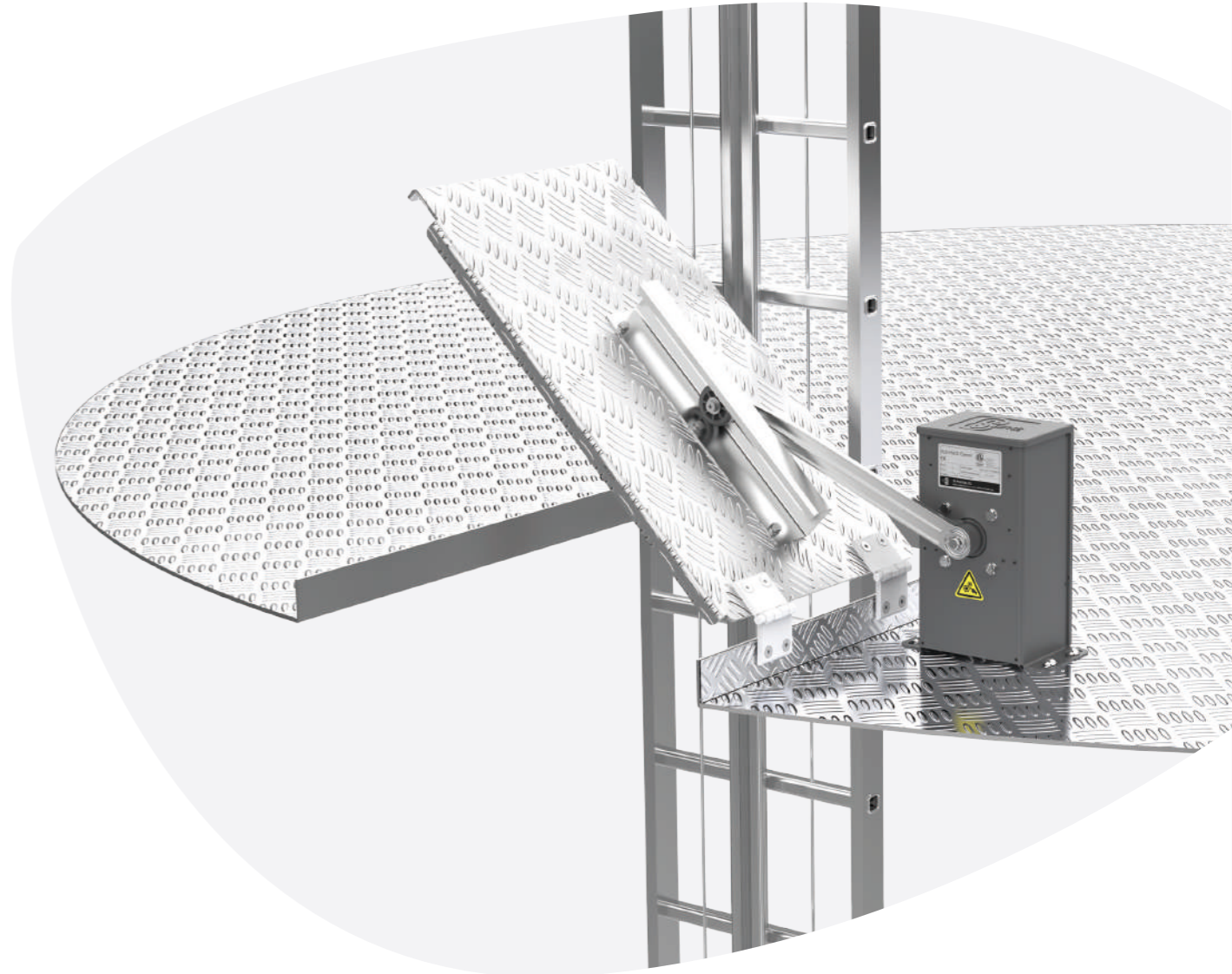

Scan to learn more



# Auto Hatch Opener

For Both Manual Climbing and Climb Auto System

**Ficont Industry (Beijing) Co., Ltd.**  
No. 11 Tongji South Road,  
Jingkai District, Beijing 100176, China  
+86 10 69597866  
info-china@3sindustry.com

**3S Americas, Inc.**  
2920 Telecom Parkway, Suite 400,  
Richardson, TX 75082, USA  
+1 972 849 3210  
info@3SAmericas.com

**3S Europe GmbH**  
Hein-Saß-Weg 21, 21129 Hamburg,  
Germany  
+49 40 32518887  
info@3SEurope.de

**3S Lift India Private Limited**  
Workafella Business Center-51, Level 4, Tower A Rattha  
Tek Meadows Old Mahabalipuram Road, Rajiv Gandhi  
Salai, Sholinganallur Chennai, Tamil Nadu, India, 600119  
+91 9600653379  
info-india@3Sindustry.com

**3S Japan Co., Ltd.**  
#B1F Bright Akihabara 1-24-9 Taito,  
Taito-Kaku, Tokyo, 110-0016 Japan  
+81 (90) 4602 3955  
info-Japan@3sindustry.com

**3S LIFT BRASIL LTDA**  
Jorge Czerniewicz street, 1020, Room 01,  
Czerniewicz zone, CEP 89.255-000,  
Jaraguá do Sul City, Santa Catarina State  
+55 11 97847-8584  
info-brasil@3sindustry.com

**3S Middle East L.L.C-FZ**  
Meydan Grandstand, 6th floor, Meydan  
Road, Nad Al Sheba, Dubai, U.A.E  
+971 50 3847134  
info-uae@3sindustry.com

# Preventing Falls From The Platform

The Auto Hatch Opener (AHO) makes operation more convenient by automatically opening and closing platform hatches as the climbing technician passes through them.

There is a risk of fatal fall injuries when technicians neglect to close platform hatches in case one of them steps into the hole in the platform. They may also accidentally drop tools through the open hatch, causing severe injuries to others working below them.

The risk of technicians banging their heads on the closed hatch is eliminated since the AHO regularly opens it for technicians. It also prevents hand and finger injuries if a technician accidentally drops the hatch on their fingers while closing it.

## Easy Installation

The AHO can be quickly and easily installed, using only a few screws to mount it.

## Compact Design

Work activities on the platform are not impaired thanks to the AHO's compact design.

## Durability

A service life of over 25 years due to the high-quality materials and robust construction.

## Maintenance-Free

The AHO requires no maintenance.

## Adaptable to Most Hatches

The AHO Hatch Opener can be to most hatch and platform types, without major structural modifications.

## Robust Temperature Resistance

The system can function in adverse temperatures ranging from -40°C to 60°C.

# Auto Hatch Opener With Manual Button

It is effective for both manual climbing and with Climb Assist. Technicians do not need to use their hands to open and close the hatch since the AHO does it automatically, eliminating a number of safety risks.

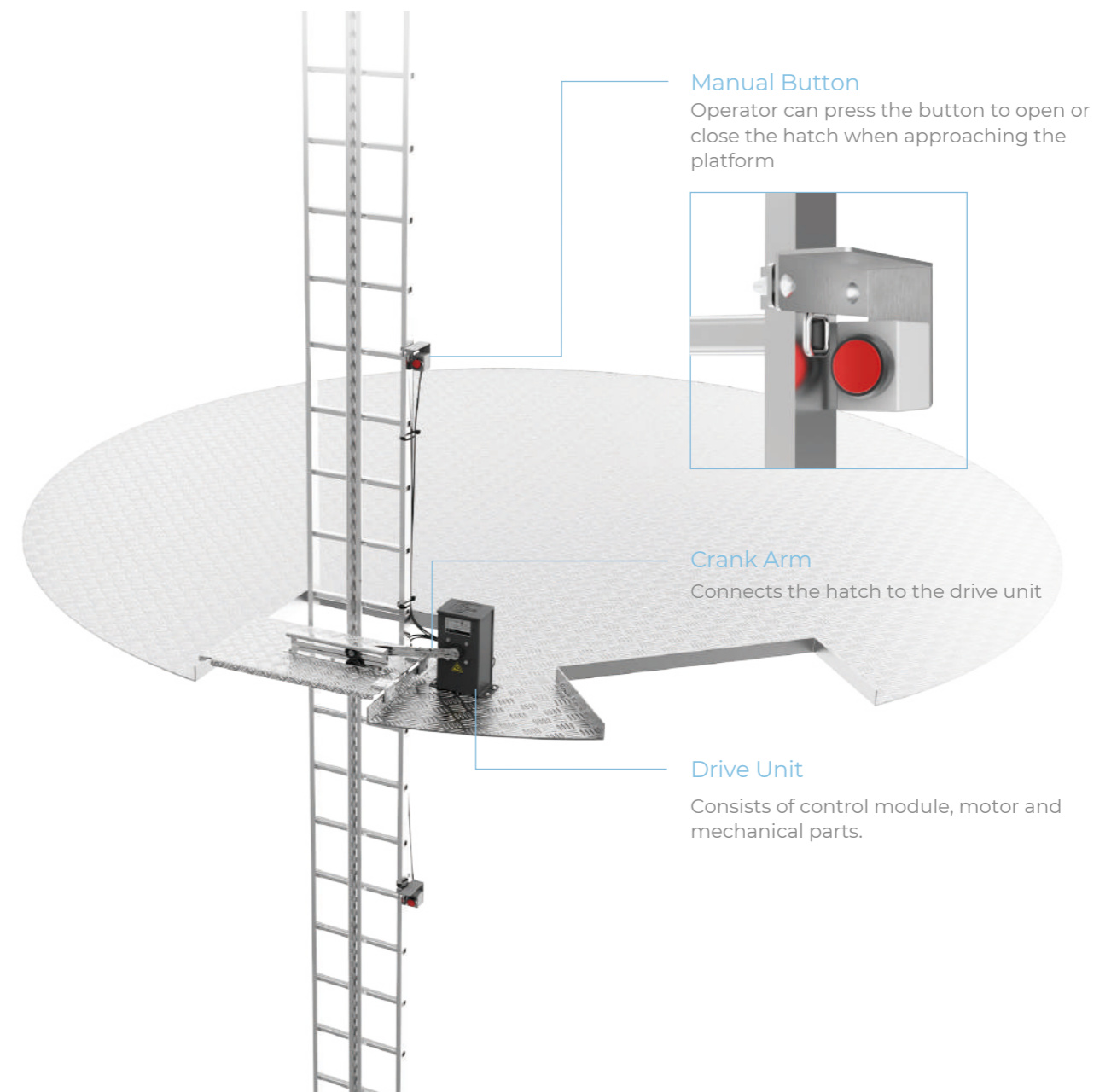

# Auto Hatch Opener with Sensor

It is effective for the Climb Auto System operation and makes CAS operation even more convenient by automatically opening and closing platform hatches as the CAS car passes through them.

## Auto Hatch Opener Specifications (With Button or Sensor)

Model	IHM-15 / IHA-15
Operation Temperature	-40°C to 60°C
Anti-Corrosion Grade	C4
Rated Voltage	Single phase, AC 230 V ±10%, 50 / 60 Hz
Power	60W
Certification	CE, EMC, ETL, UL
Protection Class	IP 44 (Higher protection class optional)
Weight	11 kg
Drive Unit Dimensions	131 x 174 x 314 mm
Crank Arm Length	400 mm



IHM-15  
Side-Opening Model



IHA-15  
Back-Opening Model



Power Cable

Upper Cable

Lower Cable